

INSTRUCTION MANUAL

VISUAL PERFORMANCE® SERIES 6" IN-WALL SPEAKERS



Introduction

Thank you for purchasing Sonance Visual Performance® Series 6" in-wall speakers. When properly installed your new speakers will give you years of entertainment pleasure. This manual covers these Visual Performance Series speaker models: VP69, VP67, VP65, VP65TL.

SAFETY WARNING:

THESE SPEAKERS HAVE FASTMOUNT® TABS THAT PREVENT THE SPEAKER FROM FALLING OUT OF THE MOUNTING HOLE DURING THE INSTALLATION PROCESS.

THE EDGES OF THE FASTMOUNT TABS ARE VERY SHARP. USE CAUTION WHEN HANDLING THE SPEAKER.

Box Contents

Each Sonance Visual Performance Series in-wall speaker box contains 2 Visual Performance Series in-wall speakers, 2 Paint plugs (installed on the fronts of the speakers), 2 Paintable grilles and 1 Mounting cutout template.

Speaker Placement

Home Theater Speaker Placement

Left, Center & Right Channels

- Place the left & right speakers on either side of the video screen, anywhere from 6 feet to 10 feet apart and 38 – 42 inches from the floor.
- If possible, locate the center speaker at the same height as the left & right channel speakers (38 – 42 inches from the floor).
- If you must place the center speaker above or below a video screen, place it no more than 2 feet above or below the center of the left and right speakers. This will maintain consistent tonality between all 3 front channel speakers.
- The main listening position should be between 8 and 12 feet away from the speakers.

Use *Figure 1* as a guide.

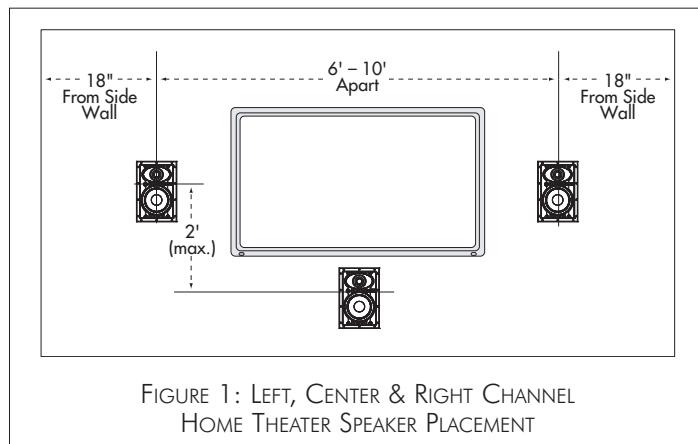

Surround Speakers (5.1-Channel System)

Locate the surround channel speakers on the side walls 2 – 6 feet behind the listening position, at least 5 feet from the floor. Use *Figure 2* as a guide.

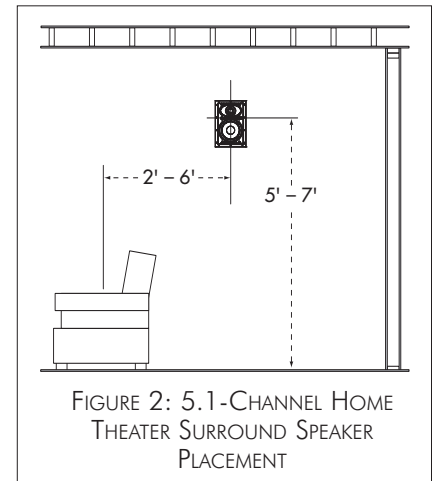

Surround Speakers (7.1-Channel System)

- **LEFT & RIGHT SURROUND SPEAKERS:** Place the left and right surround speakers directly to the sides of the listening position, at least 5 feet from the floor.
- **SURROUND BACK SPEAKERS:** Place the surround back speakers in the rear wall, between 3 feet and 6 feet apart and at least 5 feet from the floor.

Use *Figure 3* as a guide.

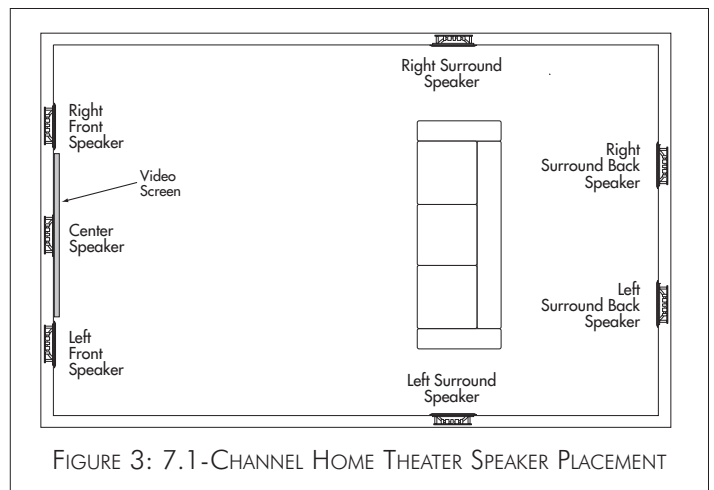

Stereo (2-Channel) Placement

- Place the left and right speakers anywhere from 6 feet to 10 feet apart, with the main listening position as close to midway between the speakers as possible.
- The speakers should be at least 2 feet away from the side walls.
- The main listening position should be between 4 and 10 feet away from the speakers.
- In most cases pivoting the tweeter of each speaker directly towards the main listening position will help maximize the stereo soundstage.

Use the left and right speaker placement in *Figure 1* as a guide.

Before Installation: Retrofit

1. Determine the location for the speaker (see *Speaker Placement* on page 1).
2. Perform an obstruction survey to be certain that there are no studs, conduit, pipes, heating ducts, pocket doors or air returns in the wall cavity that will interfere with the speaker.
3. All Visual Performance 6" in-wall speakers require a mounting cutout that is 6⁷/₈" (175mm) wide x 10³/₄" (273mm) high. The VP69, VP67 and VP65 require at least 3¹/₂" (89mm) of depth within the mounting cavity; the VP65TL requires at least 2¹/₂" (65mm) of depth within the mounting cavity.
4. Position the included cutout template where the speaker is to be located and pencil an outline on the wall.
 - If you are unsure about obstructions, drill a small hole in the center of the outline and insert a coat hanger wire into the hole to feel-around for possible obstructions.
5. Cut the mounting hole using a keyhole or drywall saw, and run the speaker wires from the mounting hole to the amplifier location.
 - Consult local building codes before running speaker wires through walls.

Before Installation: IR Plug

Sonance Visual Performance Series in-wall speakers have a plug for installing an IR receiver into the speaker's front baffle (see *Figure 4*). In systems where the electronics are placed in an inconvenient location this allows remote controls to be aimed at the front of the room instead of at the electronics.

The IR plug is in the form of a bolt and retaining nut. To remove the plug, unscrew the nut (located behind the baffle, see *Figure 5*) and remove the bolt. The hole is designed to receive a Sonance OptiLinQ® SMR1 or SMR1P Surface-Mount IR receiver. Insert the IR receiver through the front of the speaker baffle and use the nut included with the receiver to secure it to the baffle.

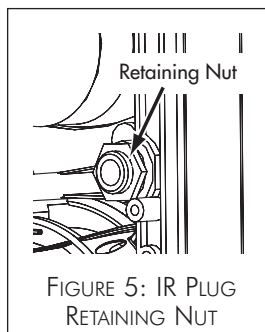
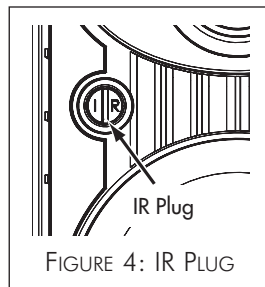

Installation

Sonance Visual Performance Series speakers feature exclusive FastMount® tabs and an integral RotoLock® mounting system for quick mounting directly into existing walls.

WARNING: THE EDGES OF THE FASTMOUNT TABS ARE VERY SHARP. USE CAUTION WHEN HANDLING THE SPEAKER.

1. Remove the paint plug from the speaker.
2. Strip 1/4" – 1/2" of insulation from each speaker lead. Twist the strands or tin the exposed wire with solder to ensure that there are no stray strands. (Stray strands that touch each other can cause a short-circuit that can damage the amplifier.)
3. The speaker's connector posts are spring-loaded. Push the top

of each connector post down to open the connector and insert the exposed wires into the holes in the posts.

- The speaker's positive post is labeled with a red dot; the negative post is labeled with a black dot. Double-check that you connected amplifier "+" to speaker "+" and amplifier "-" to speaker "-".
4. Make sure all the RotoLock clamps are retracted so that they are tucked within the mounting hole's border. Insert the speaker into the hole in the wall (*Figure 6*). The RotoLock system can accommodate a maximum wall material thickness of 1/4".

- The FastMount tabs will prevent the speaker from falling out of the mounting hole, allowing you to let go of the speaker to pick-up tools or other items (*Figure 7*).

NOTE: THE FASTMOUNT TABS ARE DESIGNED FOR ONE-TIME USE ONLY. IF THE SPEAKER IS REMOVED FROM THE MOUNTING HOLE THE FASTMOUNT TABS WILL DISCONNECT AND REMAIN INSIDE THE WALL.

5. Tighten the four screws on the front of the speaker baffle. The RotoLock clamps will automatically rotate into position and begin clamping the speaker (*Figure 8*).

- When you notice resistance on the screws the speaker has been clamped successfully.

IMPORTANT:
Always use low-torque settings;
NEVER over-tighten.

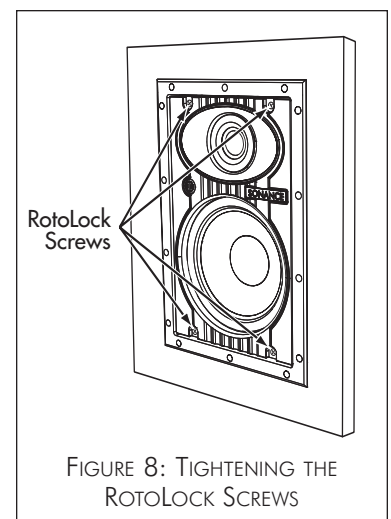
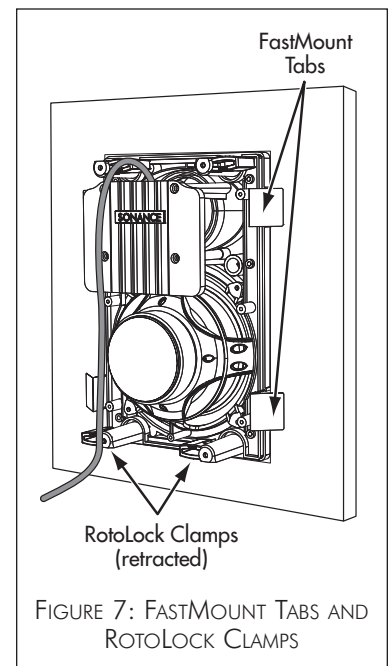
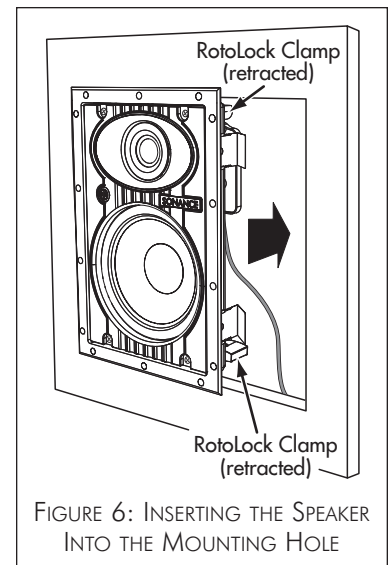

SONANCE VISUAL PERFORMANCE® 6" IN-WALL

NOTE: ADJUSTING THE TENSION OF THE ROTOLOCK CLAMPS SO THAT THE SPEAKER FRAME IS FLAT WILL HELP ENSURE THAT THE GRILLE CONTACTS THE WALL ALL THE WAY AROUND THE SPEAKER FOR A PROPER FIT.

- The new micro flange grille is held in place by several small, powerful magnets on the speaker frame. Place the grille against the speaker and the magnets will hold it firmly in place. When properly installed, the grille flange should make contact with the wall all the way around the speaker.

Painting The Grilles

See the accompanying *Painting Instructions* sheet for painting instructions.

Speaker Adjustments

Pivoting Tweeter

All Visual Performance Series 6" in-wall speakers have a pivoting tweeter that allows you to direct sound towards or away from the listening area, depending on how the speakers are being used:

- If you're using the speakers in stereo or as the front left/center/right speakers in a home theater, pivot the tweeter directly towards the listening area. This will help the sound from the speakers blend into a solid soundstage even if the speakers are widely separated.
- If you're using the speakers as surround channel speakers in a home theater, you can create a more diffuse, spacious surround effect by pivoting the tweeter towards a wall or window, away from the listeners.

To Pivot the Tweeter:

Apply light pressure to the plastic ring around the outside edge of the tweeter dome, as shown in *Figure 9*. Take care not to touch or apply pressure to the tweeter dome itself.

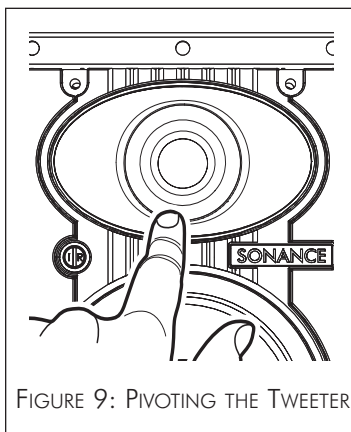

FIGURE 9: PIVOTING THE TWEETER

Specifications

VP69

Tweeter:	1" (25mm) Beryllium dome, Ferrofluid-cooled, pivoting, in acoustic back chamber
Woofer:	6½" (165mm) Beryllium cone with a rubber surround, extended pole piece
Frequency Response:	40Hz – 20kHz ±3dB
Impedance:	6 ohms nominal; 4 ohms minimum
Power Handling:	5 watts minimum; 150 watts maximum
Sensitivity:	90dB SPL (2.83V/1 meter)
Grille Material:	Perforated Steel
Dimensions (W x H x D):	7¾" x 11⅝" x 3½" (197mm x 295mm x 89mm)
Cutout Dimensions (W x H):	6⅞" x 10¾" (175mm x 273mm)
Shipping Weight:	12 lbs (5.45kg) pair

VP67

Tweeter:	1" (25mm) Aluminum dome, Ferrofluid-cooled, pivoting, in acoustic back chamber
Woofer:	6½" (165mm) Coated carbon fiber cone with a rubber surround, extended pole piece
Frequency Response:	43Hz – 20kHz ±3dB
Impedance:	6 ohms nominal; 4 ohms minimum
Power Handling:	5 watts minimum; 140 watts maximum
Sensitivity:	90dB SPL (2.83V/1 meter)
Grille Material:	Perforated Steel
Dimensions (W x H x D):	7¾" x 11⅝" x 3½" (197mm x 295mm x 89mm)
Cutout Dimensions (W x H):	6⅞" x 10¾" (175mm x 273mm)
Shipping Weight:	11 lbs (5.0kg) pair

VP65/VP65TL

Tweeter:	1" (25mm) Silk dome, Ferrofluid-cooled, pivoting, in acoustic back chamber
Woofer:	6½" (165mm) Carbon fiber cone with a rubber surround
Frequency Response:	44Hz – 20kHz ±3dB
Impedance:	8 ohms nominal; 6 ohms minimum
Power Handling:	5 watts minimum; 130 watts maximum
Sensitivity:	90dB SPL (2.83V/1 meter)
Grille Material:	Perforated Steel
Dimensions	
VP65 (W x H x D):	7¾" x 11⅝" x 3½" (197mm x 295mm x 89mm)
VP65TL (W x H x D):	8¼" x 12⅜" x 2½" (210mm x 310mm x 65mm)
Cutout Dimensions (W x H):	6⅞" x 10¾" (175mm x 273mm)
Shipping Weight:	10 lbs (4.5kg) pair

Technical Assistance and Service

If you any have questions about the operation or installation of this product, please call our Technical Assistance Department on any business day at (800) 582-0772 or (949) 492-7777; from 7 a.m. to 5 p.m., PST.

If your speakers should need repair or service, contact your Sonance Authorized Dealer for help, or use the following procedure:

1. Prior to calling, note the product's model number, serial number, purchase date, and the name and address of the dealer where you purchased the product.
2. Contact our Technical Assistance Department at the above number(s) and describe the problem the unit is experiencing. If applicable, they will issue a Return Authorization Number.

IMPORTANT: YOU MUST HAVE PRIOR AUTHORIZATION TO RETURN YOUR SPEAKER TO SONANCE!

3. If you're directed to return the unit to Sonance for repair, pack the unit in its original shipping carton. If needed, you can obtain replacement packaging from us for a small charge. Note: it is best if you place the box into an additional outer "overcarton" before shipment to minimize a chance of theft in shipment. Please include a copy of the original bill of sale inside the package.
4. Contact a package delivery company such as United Parcel Service or Federal Express to arrange prepaid (not collect) shipping. Do not use the U.S. Postal Service.

IMPORTANT: Freight collect shipments will be refused.

5. Write the Return Authorization Number on the outside of the shipping carton.

6. Ship the packaged unit to:

**Quality Assurance Department
Sonance
212 Avenida Fabricante
San Clemente, CA 92672-7531**

Limited Lifetime Warranty Coverage (U.S. Only)

Sonance warrants to the original retail purchaser only that this Sonance product will be free from defects in materials and workmanship, provided the speaker was purchased from a Sonance Authorized Dealer.

Defective products must be shipped, together with proof of purchase, prepaid insured to the Authorized Sonance Dealer from whom they were purchased, or to the Sonance factory at the address listed on this instruction manual. Freight collect shipments will be refused. It is preferable to ship this product in the original shipping container to lessen the chance of transit damage. In any case, the risk or loss or

damage in transit is to be borne by the purchaser. If upon examination at the factory or Authorized Sonance Dealer it is determined that the unit was defective in materials or workmanship at any time during this warranty period, Sonance or the Authorized Sonance Dealer will, at its option, repair or replace this product at no additional charge, except as set forth below. If this model is no longer available and can not be repaired effectively, Sonance, at its sole option, may replace the unit with a current model of equal or greater value. In some cases where a new model is substituted, a modification to the mounting surface may be required. If mounting surface modification is required, Sonance assumes no responsibility or liability for such modification. All replaced parts and product become the property of Sonance. Products replaced or repaired under this warranty will be returned to the original retail purchaser, within a reasonable time, freight prepaid.

This Warranty does not include service or parts to repair damage caused by accident, disaster, misuse, abuse, negligence, inadequate packing or shipping procedures, commercial use, voltage inputs in excess of the rated maximum of the unit, or service, repair or modification of the product which has not been authorized or approved by Sonance. This Warranty also excludes normal cosmetic deterioration caused by environmental conditions. This Warranty will be void if the Serial Number on the product has been removed, tampered-with or defaced. This Warranty is in lieu of all other expressed warranties. If the product is defective in materials or workmanship as warranted above, the purchaser's sole remedy shall be repair or replacement as provided above. In no event will Sonance be liable for any incidental or consequential damages arising out of the use or inability to use the product, even if Sonance or an Authorized Sonance Dealer has been advised of the possibility of such damages, or for any claim by any other party.

Some states do not allow the exclusion or limitation of consequential damages, so the above limitation and exclusion may not apply. All implied warranties on the product are limited to the duration of this expressed Warranty. Some states do not allow limitation on the length of an implied warranty. If the original retail purchaser resides in such a state, this limitation does not apply.

Exclusions And Limitations

The warranty set forth above is in lieu of all other warranties, express or implied, of merchantability, fitness for a particular purpose, or otherwise. The warranty is limited to Sonance products registered herein and specifically excludes any damage to loudspeakers and other allied or associated equipment which may result for any reason from use with this product. Sonance shall, in no event, be liable for incidental or consequential damages arising from any breach of this warranty or otherwise. This warranty gives you specific legal rights, and you may have other rights which vary from state to state.



SONANCE®

©2008 Sonance. All rights reserved.

Sonance, Sonance Visual Performance, RotoLock and FastMount are registered trademarks of Dana Innovations.

Due to continuous product improvement, all features and specifications are subject to change without notice.

For the latest Sonance product specification information visit our website: www.sonance.com

SONANCE • 212 Avenida Fabricante • San Clemente, CA 92672-7531 USA

(800) 582-7777 or (949) 492-7777 • FAX: (949) 361-5151 • Technical Support: (800) 582-0772

www.sonance.com

33-4786 06/08