

INSTRUCTION MANUAL

VISUAL PERFORMANCE® SERIES 8" IN-CEILING SPEAKERS



Introduction

Thank you for purchasing Sonance Visual Performance® Series 8" in-ceiling speakers. When properly installed your new speakers will give you years of entertainment pleasure. This manual covers these Visual Performance series speaker models: VP89R, VP87R, VP85R, VP85S.

SAFETY WARNING:

THESE SPEAKERS HAVE FASTMOUNT® TABS THAT PREVENT THE SPEAKER FROM FALLING OUT OF THE MOUNTING HOLE DURING THE INSTALLATION PROCESS.

THE EDGES OF THE FASTMOUNT TABS ARE VERY SHARP. USE CAUTION WHEN HANDLING THE SPEAKER.

Box Contents

Sonance Visual Performance Series in-ceiling speaker boxes contain (2) Visual Performance speakers, (2) paint plugs (installed on the fronts of the speakers), (2) paintable grilles and (1) mounting cutout template.

Speaker Placement

Distributed Audio Placement (Mono signal)

All Sonance Visual Performance Series in-ceiling speaker models provide excellent coverage in distributed audio systems from a wide variety of installation locations.

The table and illustration in Figure 1 show how far apart the speakers can be placed at various ceiling heights while still providing good coverage for all listeners.

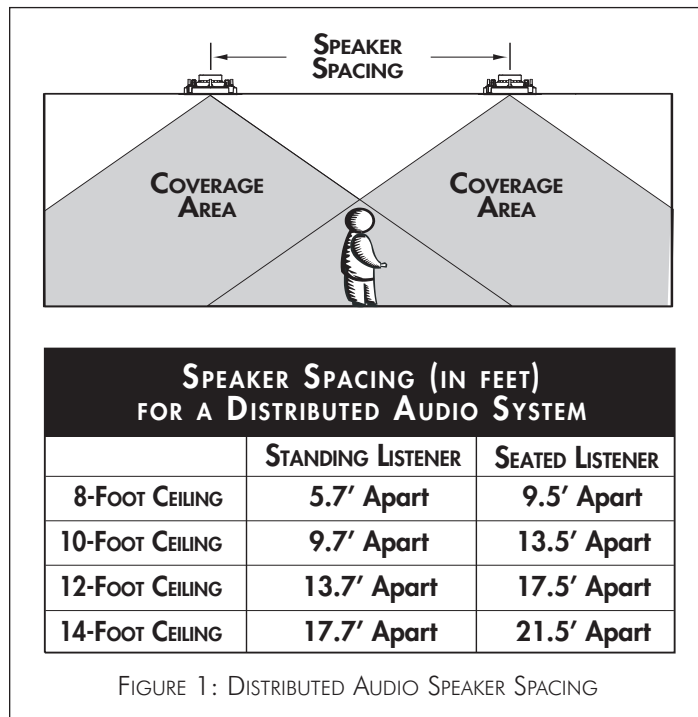

FIGURE 1: DISTRIBUTED AUDIO SPEAKER SPACING

Home Theater Speaker Placement

Left, Center & Right Speakers (see Figure 2)

- Place the left, center and right speakers from 1 foot to 2 feet in front of the video screen, from 6 feet to 10 feet apart, with the center channel speaker as close to midway between the left and right speakers as possible.
- The main listening position should be between 4 and 10 feet away from the speakers.

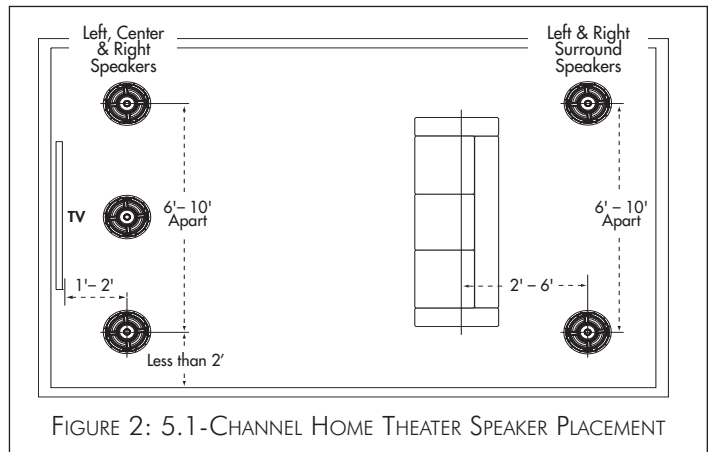

FIGURE 2: 5.1-CHANNEL HOME THEATER SPEAKER PLACEMENT

Surround Speakers — 5.1-Channel System (see Figure 2)

- Locate the left and right surround speakers between 2 feet and 6 feet behind the listening position. The speakers should be between 6 feet and 10 feet apart.

Surround Speakers — 7.1-Channel System (see Figure 3)

- Left & Right Surround Speakers:** Place the left and right surround speakers directly to the sides of the listening position, between 6 feet and 10 feet apart.
- Surround Back Speakers:** Place the surround back speakers between 2 feet and 6 feet behind the listening position. The surround back speakers should be closer together than the left and right surround speakers — between 3 feet and 6 feet apart.

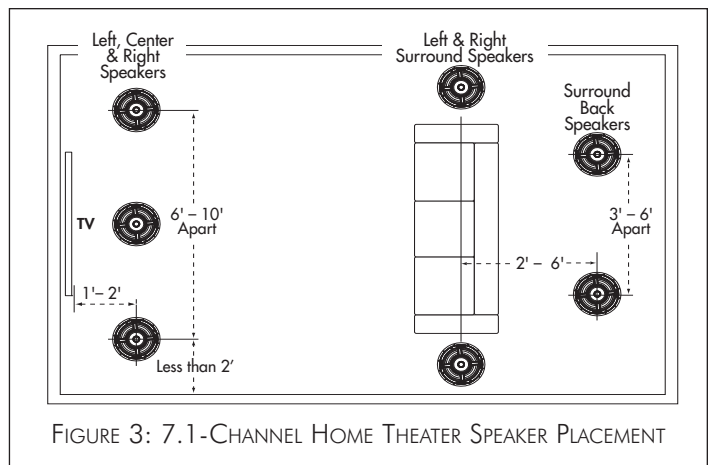

FIGURE 3: 7.1-CHANNEL HOME THEATER SPEAKER PLACEMENT

Stereo Placement (2-Channel)

- Place the left and right speakers anywhere from 6 feet to 10 feet apart, with the main listening position as close to midway between the speakers as possible.
- In most cases pivoting the woofer and/or midrange/tweeter assembly of each speaker directly towards the main listening position will help maximize the stereo soundstage.

Use the Left and Right speaker placement in *Figures 2 and 3* (on page 1) as a guide.

Before Installation

1. Determine the location for the speaker (see *Speaker Placement* on page 1).
2. Perform an obstruction survey to be certain that there are no studs, conduit, pipes, heating ducts, pocket doors or air returns in the ceiling cavity that will interfere with the speaker.
3. Visual Performance Series 8" in-ceiling speakers have the following mounting space requirements:
 - VP89R/VP87R/VP85R: 10¹/₈" (257mm) diameter mounting hole with at least 5⁷/₈" (149mm) depth within the mounting cavity.
 - VP85S: 10¹/₈" x 10¹/₈" (257mm x 257mm) mounting hole with at least 6" (152mm) depth within the mounting cavity.
4. Position the included cutout template where the speaker is to be located and pencil an outline on the ceiling.
 - If you are unsure about obstructions, drill a small hole in the center of the outline and insert a coat hanger wire into the hole to feel-around for possible obstructions.
5. Cut the mounting hole using a keyhole or drywall saw, and run the speaker wires from the mounting hole to the amplifier location.
 - Consult local building codes before running speaker wires through ceilings.

Installation

Sonance Visual Performance Series speakers feature exclusive FastMount® tabs and an integral RotoLock® mounting system for quick mounting directly into existing ceilings.

WARNING: THE EDGES OF THE FASTMOUNT TABS ARE VERY SHARP. USE CAUTION WHEN HANDLING THE SPEAKER.

1. Remove the paint plug from the speaker.
2. Strip 1/4" – 1/2" of insulation from each speaker lead. Twist the strands or tin the exposed wire with solder to ensure that there are no stray strands. (Stray strands that touch each other can cause a short-circuit that can damage the amplifier.)
3. The speaker's connector posts are spring-loaded. Push the top of each connector post down to open the connector and insert the exposed wires into the holes in the posts.
 - The speaker's positive post is labeled with a red dot; the negative post is labeled with a black dot. Double-check that you connected amplifier "+" to speaker "+" and amplifier "-" to speaker "-".
4. Make sure all the RotoLock clamps are retracted so that they are tucked within the mounting hole's border. Insert the speaker into the hole in the ceiling (*Figure 4*, next column).

The RotoLock system can accommodate a maximum ceiling material thickness of 1 1/4".

- The FastMount tabs will prevent the speaker from falling out of the mounting hole, allowing you to let go of the speaker to pick-up tools or other items (*Figure 5*).

NOTE: THE FASTMOUNT TABS ARE DESIGNED FOR ONE-TIME USE ONLY. IF THE SPEAKER IS REMOVED FROM THE MOUNTING HOLE THE FASTMOUNT TABS WILL DISCONNECT AND REMAIN INSIDE THE CEILING.

5. Tighten the four screws on the front of the speaker baffle. The RotoLock clamps will automatically rotate into position and begin clamping the speaker (*Figure 6*).

- When you notice resistance on the screws the speaker has been clamped successfully.

IMPORTANT: Always use low-torque settings; NEVER over-tighten.

NOTE: ADJUST THE TENSION OF THE ROTOLOCK CLAMPS SO THAT THE SPEAKER FRAME IS FLAT. THIS WILL HELP ENSURE THAT THE GRILLE CONTACTS THE CEILING ALL THE WAY AROUND THE SPEAKER FOR A PROPER FIT.

6. The new micro flange grille is held in place by several small, powerful magnets on the speaker frame. Place the grille against the speaker and the magnets will hold it firmly in place. When properly installed, the grille flange should make contact with the wall all the way around the speaker.

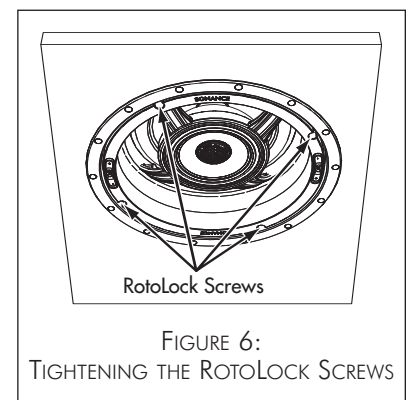
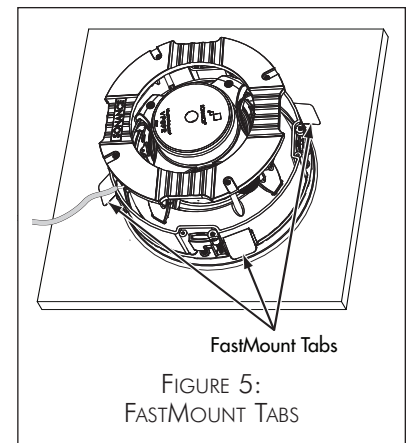
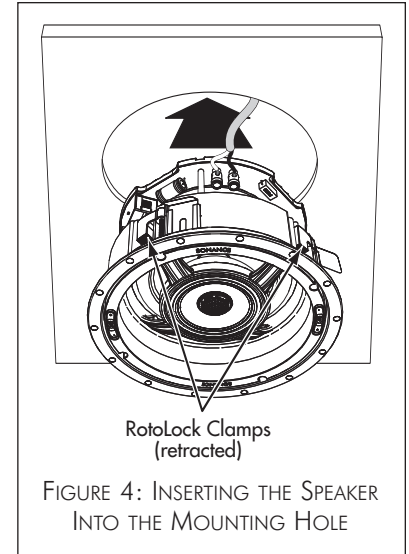

SONANCE VISUAL PERFORMANCE® 8" IN-CEILING

Painting The Grilles

Visual Performance speaker grilles completely cover the speaker frame, so only the grilles (not the speakers themselves) require painting. The speakers are fitted with paint plugs to protect them if the ceiling is painted after the speakers are installed.

To paint the grilles, first remove the scrim cloth that is attached to the backs of the grilles. (The adhesive that holds the cloth in place is reusable.) Paint the grilles with very thin paint (5 parts thinner to 1 part paint), being careful not to plug the holes. When the paint has fully dried, re-attach the scrim cloths to the backs of the grilles and re-install the grilles on the speakers.

Speaker Adjustments

Pivoting Woofer and Midrange/Tweeter

All Visual Performance Series 8" in-ceiling speakers have a pivoting woofer and a pivoting midrange/tweeter assembly. If you're using the speakers in stereo or as the front left/center/right speakers in a home theater, pivot the drivers directly towards the listening area. If you're using the speakers as surround channel speakers in a home theater, pivot the drivers towards a wall or window, away from the listeners.

To pivot the midrange/tweeter assembly, apply light pressure to the ring around the outside edge of the midrange cone, as shown in *Figure 7*, left. Take care not to touch or apply pressure to the midrange cone itself. To Pivot the woofer, apply pressure on the outer edge of one of the tweeter support brackets, as shown in *Figure 7*, right. Do not touch or apply pressure to the woofer cone.

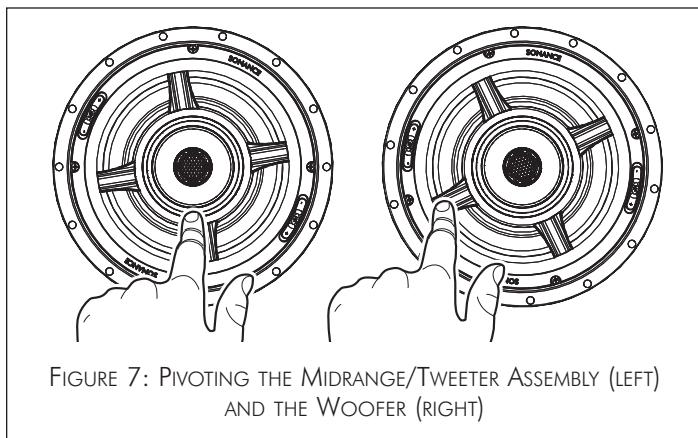

FIGURE 7: PIVOTING THE MIDRANGE/TWEETER ASSEMBLY (LEFT) AND THE WOOFER (RIGHT)

Tweeter and Midrange Level Switches

The VP89R and VP87R have midrange and tweeter level switches (see *Figure 8*) that boost or cut those drivers' levels by 3dB. This lets you tailor the speaker's performance to better match the room's acoustics or the listener's preferences.

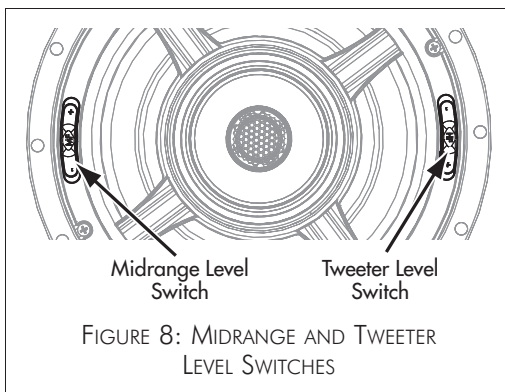

FIGURE 8: MIDRANGE AND TWEETER LEVEL SWITCHES

Specifications

VP89R

Tweeter:	1" (25mm) Beryllium dome, Ferrofluid-cooled, pivoting
Midrange:	4" (102mm) Beryllium cone with a rubber surround, pivoting
Woofer:	8" (203mm) Beryllium cone with a rubber surround, pivoting
Frequency Response:	30Hz – 20kHz ±3dB
Impedance:	6 ohms nominal; 4 ohms minimum
Power Handling:	5 watts minimum; 175 watts maximum
Sensitivity:	91dB SPL (2.83V/1 meter)
Grille Material:	Perforated steel
Adjustments:	Tweeter and midrange level (±3dB)
Dimensions (Dia. x D):	11 ⁵ / ₈ " x 5 ⁷ / ₈ " (295mm x 149mm)
Cutout Dimensions (Dia):	10 ¹ / ₈ " (257mm)
Shipping Weight:	22 lbs (10.0kg) pair

VP87R

Tweeter:	1" (25mm) Aluminum dome, Ferrofluid-cooled, pivoting
Midrange:	4" (102mm) Coated carbon fiber cone with a rubber surround, pivoting
Woofer:	8" (203mm) Coated carbon fiber cone with a rubber surround, pivoting
Frequency Response:	31Hz – 20kHz ±3dB
Impedance:	6 ohms nominal; 4 ohms minimum
Power Handling:	5 watts minimum; 165 watts maximum
Sensitivity:	91dB SPL (2.83V/1 meter)
Grille Material:	Perforated steel
Adjustments:	Tweeter and midrange level (±3dB)
Dimensions (Dia. x D):	11 ⁵ / ₈ " x 5 ⁷ / ₈ " (295mm x 149mm)
Cutout Dimensions (Dia):	10 ¹ / ₈ " (257mm)
Shipping Weight:	22 lbs (10.0kg) pair

VP85R/VP85S

Tweeter:	1" (25mm) Silk dome, Ferrofluid-cooled, pivoting
Midrange:	4" (102mm) Carbon fiber cone with a rubber surround, pivoting
Woofer:	8" (203mm) Carbon fiber cone with a rubber surround, pivoting
Frequency Response:	36Hz – 20kHz ±3dB
Impedance:	8 ohms nominal; 6 ohms minimum
Power Handling:	5 watts minimum; 140 watts maximum
Sensitivity:	91dB SPL (2.83V/1 meter)
Grille Material:	Perforated Steel
Dimensions	
VP85R (Dia. x D):	11 ⁵ / ₈ " x 5 ⁷ / ₈ " (295mm x 149mm)
VP85S (H x W x D):	11 ¹ / ₄ " x 11 ¹ / ₄ " x 6" (286mm x 186mm x 152mm)
Cutout Dimensions	
VP85R (Dia):	10 ¹ / ₈ " (257mm)
VP85S (W x H):	10 ¹ / ₈ " x 10 ¹ / ₈ " (257mm x 257mm)
Shipping Weight:	20 lbs (9.0kg) pair

Technical Assistance and Service

If you any have questions about the operation or installation of this product, please call our Technical Assistance Department on any business day at (800) 582-0772 or (949) 492-7777; from 7 a.m. to 5 p.m., PST.

If your speakers should need repair or service, contact your Sonance Authorized Dealer for help, or use the following procedure:

1. Prior to calling, note the product's model number, serial number, purchase date, and the name and address of the dealer where you purchased the product.
2. Contact our Technical Assistance Department at the above number(s) and describe the problem the unit is experiencing. If applicable, they will issue a Return Authorization Number.

IMPORTANT: YOU MUST HAVE PRIOR AUTHORIZATION TO RETURN YOUR SPEAKER TO SONANCE!

3. If you're directed to return the unit to Sonance for repair, pack the unit in its original shipping carton. If needed, you can obtain replacement packaging from us for a small charge. Note: it is best if you place the box into an additional outer "overcarton" before shipment to minimize a chance of theft in shipment. Please include a copy of the original bill of sale inside the package.
4. Contact a package delivery company such as United Parcel Service or Federal Express to arrange prepaid (not collect) shipping. Do not use the U.S. Postal Service.

IMPORTANT: Freight collect shipments will be refused.

5. Write the Return Authorization Number on the outside of the shipping carton.

6. Ship the packaged unit to:

**Quality Assurance Department
Sonance
212 Avenida Fabricante
San Clemente, CA 92672-7531**

Limited Lifetime Warranty Coverage (U.S. Only)

Sonance warrants to the original retail purchaser only that this Sonance product will be free from defects in materials and workmanship, provided the speaker was purchased from a Sonance Authorized Dealer.

Defective products must be shipped, together with proof of purchase, prepaid insured to the Authorized Sonance Dealer from whom they were purchased, or to the Sonance factory at the address listed on this instruction manual. Freight collect shipments will be refused. It is preferable to ship this product in the original shipping container to lessen the chance of transit damage. In any case, the risk or loss or

damage in transit is to be borne by the purchaser. If upon examination at the factory or Authorized Sonance Dealer it is determined that the unit was defective in materials or workmanship at any time during this warranty period, Sonance or the Authorized Sonance Dealer will, at its option, repair or replace this product at no additional charge, except as set forth below. If this model is no longer available and can not be repaired effectively, Sonance, at its sole option, may replace the unit with a current model of equal or greater value. In some cases where a new model is substituted, a modification to the mounting surface may be required. If mounting surface modification is required, Sonance assumes no responsibility or liability for such modification. All replaced parts and product become the property of Sonance. Products replaced or repaired under this warranty will be returned to the original retail purchaser, within a reasonable time, freight prepaid.

This Warranty does not include service or parts to repair damage caused by accident, disaster, misuse, abuse, negligence, inadequate packing or shipping procedures, commercial use, voltage inputs in excess of the rated maximum of the unit, or service, repair or modification of the product which has not been authorized or approved by Sonance. This Warranty also excludes normal cosmetic deterioration caused by environmental conditions. This Warranty will be void if the Serial Number on the product has been removed, tampered-with or defaced. This Warranty is in lieu of all other expressed warranties. If the product is defective in materials or workmanship as warranted above, the purchaser's sole remedy shall be repair or replacement as provided above. In no event will Sonance be liable for any incidental or consequential damages arising out of the use or inability to use the product, even if Sonance or an Authorized Sonance Dealer has been advised of the possibility of such damages, or for any claim by any other party.

Some states do not allow the exclusion or limitation of consequential damages, so the above limitation and exclusion may not apply. All implied warranties on the product are limited to the duration of this expressed Warranty. Some states do not allow limitation on the length of an implied warranty. If the original retail purchaser resides in such a state, this limitation does not apply.

Exclusions And Limitations

The warranty set forth above is in lieu of all other warranties, express or implied, of merchantability, fitness for a particular purpose, or otherwise. The warranty is limited to Sonance products registered herein and specifically excludes any damage to loudspeakers and other allied or associated equipment which may result for any reason from use with this product. Sonance shall, in no event, be liable for incidental or consequential damages arising from any breach of this warranty or otherwise. This warranty gives you specific legal rights, and you may have other rights which vary from state to state.



SONANCE®

©2008 Sonance. All rights reserved.

Sonance, Sonance Visual Performance, RotoLock and FastMount are registered trademarks of Dana Innovations.

Due to continuous product improvement, all features and specifications are subject to change without notice.

For the latest Sonance product specification information visit our website: www.sonance.com

SONANCE • 212 Avenida Fabricante • San Clemente, CA 92672-7531 USA

(800) 582-7777 or (949) 492-7777 • FAX: (949) 361-5151 • Technical Support: (800) 582-0772

www.sonance.com

33-4790 06/08